

GMH Plus

Analog Mobile Radio

Owner's Manual



BK RADIO

TABLE OF CONTENTS

FCC Requirements	2
Safety Precautions	2
RF Energy Exposure Awareness And Control Information	3
Radio Controls	6
Basic Operation	6
Channel Guard Operation	7
Channel Groups	8
Programmable Push Buttons/ Microphone FCN Key Menu	9
Scan Operation	12
Priority Scan	14
User Selected Channel Guard	18
Other Operational Features	18
Alphanumeric Display	21
Definitions And Acronyms	23
Programming Notes	24

INTRODUCTION

This section contains information concerning the operational procedures for BK Radio GMH Plus Flex•Mode mobile radios. BK Radio Flex•Mode radios are designed to operate on both 12.5 kHz and 25 kHz analog radio systems. GMH Plus features include 400 channels with an operating frequency of 136-174 MHz. Please take a moment to read the information in this manual so you can get optimum performance from your new radio.

FCC REQUIREMENTS

Your radio must be properly licensed by the Federal Communications Commission prior to use. Your BK Radio dealer can assist you in meeting these requirements. Your dealer will program each radio with your authorized frequencies, signaling codes, etc., and will be there to meet your communications needs as your system expands.

SAFETY PRECAUTIONS



- Do not operate the transmitter in close proximity to blasting caps.
- Do not operate the radio in an explosive atmosphere (petroleum fuels, solvents, dust, etc.).
- Do not operate the transmitter if a person outside the vehicle is less than three feet from the antenna or touching the antenna.

RF ENERGY EXPOSURE AWARENESS AND CONTROL INFORMATION, AND OPERATIONAL INSTRUCTIONS FOR FCC

OCCUPATIONAL USE REQUIREMENTS

BEFORE USING YOUR MOBILE 2-WAY RADIO, READ THE INFORMATION BELOW WHICH CONTAINS IMPORTANT OPERATING INSTRUCTIONS FOR SAFE USAGE AND RF ENERGY AWARENESS AND CONTROL INFORMATION FOR COMPLIANCE WITH RF ENERGY EXPOSURE LIMITS IN APPLICABLE NATIONAL AND

INTERNATIONAL STANDARDS.

NOTICE: This radio is intended for use in occupational/controlled conditions, where users have full knowledge of their exposure and can exercise control over their exposure to meet FCC limits. This radio device is NOT authorized for general population, consumer, or any other use.

This 2-way radio uses electromagnetic energy in the radio frequency (RF) spectrum to provide communications between two or more users over a distance. It uses radio frequency (RF) energy or radio waves to send and receive calls. RF energy is one form of electromagnetic energy; other forms include, but are not limited to, sunlight and x-rays. RF energy, however, should not be confused with these other forms of electromagnetic energy, which when used improperly, can cause biological damage. Very high levels of x-rays, for example, can damage tissues and genetic material.

Experts in science, engineering, medicine, health and industry work with organizations to develop standards for exposure to RF energy. These standards provide recommended levels of RF exposure for both workers and the general public. These recommended RF exposure levels include substantial margins of protection. All 2-way radios are designed, manufactured, and tested to ensure they meet government established RF exposure levels. In addition, manufacturers also recommend specific operating instructions to users of 2-way radios.

These instructions are important because they inform users about RF energy exposure and provide simple procedures on how to control it. Please refer to the following websites for more information on what RF energy exposure is and how to control your exposure to assure compliance with established RF exposure limits.

<http://www.fcc.gov/oet/rfsafety/rf-faqs.html>

<http://www.osha.gov/SLTC/radiofrequencyradiation/index.html>

FEDERAL COMMUNICATIONS COMMISSION REGULATIONS

The FCC rules require manufacturers to comply with the FCC RF energy exposure limits for mobile 2-way radios before they can be marketed in the U.S. When 2-way radios are used as a consequence of employment, the FCC requires users to be fully aware of and able to control their exposure to meet occupational requirements. Exposure awareness can be facilitated by the use of a product label directing users to specific user awareness information. Your BK Radio 2-way radio has an RF exposure product label. Also, your BK Radio owner's and service manuals include information and operating instructions required to control your RF exposure and to satisfy compliance requirements.

COMPLIANCE WITH RF EXPOSURE STANDARDS

Your BK Radio 2-way radio is designed and tested to comply with a number of national and international standards and guidelines (listed below) for human exposure to radio frequency electromagnetic energy. This radio complies with the IEEE and ICNIRP exposure limits for occupational/controlled RF exposure environment at operating duty factors of up to 50% talk-50% listen and is authorized by the FCC for occupational use only. In terms of measuring RF energy for compliance with the FCC exposure guidelines, your radio antenna radiates measurable RF energy only while it is transmitting (during talking), not when it is receiving (listening) or in Standby Mode.

Your BK Radio 2-way radio complies with the following RF energy exposure standards and guidelines:

- United States Federal Communications Commission, Code of Federal Regulations; 47 CFR §§ 1.1307, 1.1310, 2.1091 and 2.1093
- American National Standards Institute (ANSI) / Institute of Electrical and Electronic Engineers (IEEE) C95. 1-1992
- Institute of Electrical and Electronic Engineers (IEEE) C95.1-1999 Edition
-

INDUSTRY CANADA COMPLIANCE

This Class B digital apparatus complies with Canadian ICES-003.

Cet appareil numérique de la classe B est conforme à la norme NMB-003 Canada.

RF EXPOSURE COMPLIANCE AND CONTROL GUIDELINES AND OPERATING INSTRUCTIONS

To control exposure to yourself and others and to ensure compliance with the RF exposure limits, always adhere to the following procedures.

Guidelines:

- User awareness instructions must accompany device when transferred to other users.
- Do not use this device if the operational requirements described herein are not met.

Operating Instructions:

- **Transmit no more than the rated duty factor of 50% of the time.** To transmit (talk), push the Push-To-Talk (PTT) button. The red LED will illuminate when the radio is transmitting. To receive calls, release the PTT button. The red LED will extinguish when the radio stops transmitting. Transmitting 50% of the time, or less, is important because this radio generates measurable RF energy exposure only when transmitting (in terms of measuring for standards compliance).
- **Transmit only when persons around the vehicle are at least 3 feet (90 centimeters) away from the vehicle with a properly installed antenna.** This separation distance will ensure that there is sufficient distance from a properly installed (according to installation instructions) externally-mounted antenna to satisfy the RF exposure requirements in the standards listed above.

CONTACT INFORMATION

For additional information on exposure requirements or other information, visit website <http://www.relm.com>.

RADIO CONTROLS

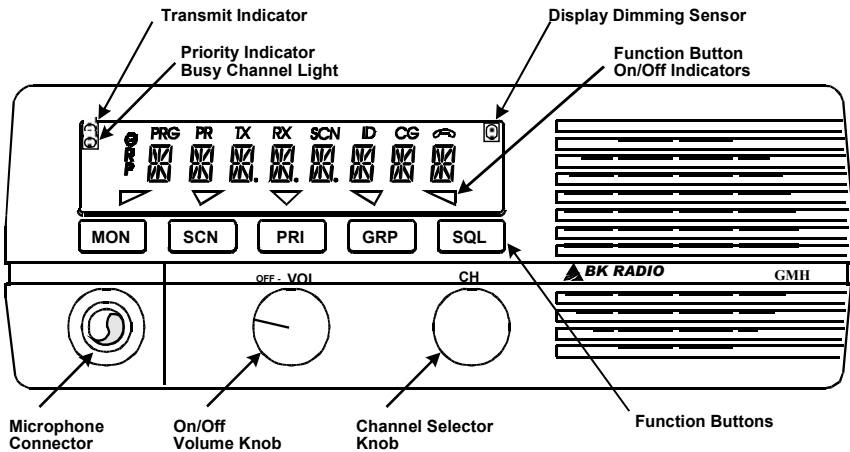

BASIC OPERATION

RECEIVE

1. Turn power on by pushing and releasing the Volume knob. The radio will beep, indicating that it has passed its self test and is operational.
2. Set volume by pressing the **[MON]** button to hear squelch noise. Turn the Volume knob to set a comfortable volume level. Press the **[MON]** button again to stop squelch noise.
3. Select a channel group (if applicable) by pressing the **[GRP]** button and turning the Channel Selector knob. Press the **[GRP]** button again to return to Channel Select mode.
4. Select a channel by turning the Channel Selector knob. When the unstopped channel selector is rotated past the highest (16th) channel, the radio will emit a beep and remain on the highest channel. When rotated past the lowest (1st) channel, the radio will emit a beep and remain on the lowest channel.

The display can show channel numbers (Numeric Mode), channel labels (Alphanumeric Mode), or receive and transmit frequencies. The Display Mode and Channel Labels are programmed by the technician along with Group Labels (if applicable) and channel frequencies. The display shows slightly different indications during Channel Scan and Priority Scan operation in alphanumeric and numeric modes.

TRANSMIT

1. Press the PTT (Push-To-Talk) switch on the microphone. The TX annunciator appears on the display and the red Transmit indicator illuminates while the PTT is pressed.
2. Talk in a normal voice with the microphone approximately one to two inches from your mouth.
3. Release the PTT switch to stop transmitting.

If the TX annunciator does not appear and a tone is heard, you are on a receive-only channel or the channel is busy (if Busy Channel Lockout is enabled). Turn the Channel Selector knob to an authorized transmit channel or wait until the channel is clear (if Busy Channel Lockout is enabled).

If the length of your transmission exceeds the preset Time-Out Timer setting, the transmitter automatically shuts off and a tone sounds. To continue the transmission, release the PTT switch, then press it again and continue talking.

CHANNEL GUARD OPERATION

Channel Guard allows one radio or group of radios to be selectively called within a system. If the radio has been programmed with Channel Guard, use the following receive and transmit instructions.

SQUELCH CONTROL

Sub-audible signaling (CTCSS/CDCSS) is used to allow a group of radios to be selectively called in a system. Programming the receive guard equal to zero allows for Carrier Squelch operation, where the radio will unmute whenever a carrier is detected.

CHANNEL GUARD RECEIVE

1. Turn power on by pushing and releasing the Volume knob. The radio will beep, indicating that it has passed its self test and is operational.
2. Set volume by pressing the **[MON]** button to hear squelch noise. Turn the Volume knob to set a comfortable volume level. Press the **[MON]** button again to stop squelch noise.
3. Select a channel group (if applicable) by pressing the **[GRP]** button and turning the Channel Selector knob. Press the **[GRP]** button again to return to Channel Select mode.

4. Select a channel by turning the Channel Selector knob.
5. Press the **[CG]** button to disable or enable Channel Guard operation. An arrow on the display points to the **[CG]** button indicating when Channel Guard is disabled. When Channel Guard is disabled the radio reverts to carrier squelch and all transmission on the assigned receive frequency will be heard. When Channel Guard is enabled, a message is heard only when the proper Channel Guard is received.

CHANNEL GUARD TRANSMIT

1. Before transmitting on Channel Guard channels monitor the channel by lifting the microphone off hook or pressing the **[MON]** button. Listen to the channel for a few seconds to ensure that no communications are occurring on the channel.
2. Press the PTT (Push-To-Talk) switch on the microphone. The TX annunciator appears on the display and the red Transmit indicator illuminates while the PTT is pressed. Talk in a normal voice with the microphone approximately one to two inches from your mouth. Release the PTT switch to stop transmitting.
3. Hang up the microphone when finished. If you pressed the **[MON]** button to monitor the channel, press it again after the transmission to return to Channel Guard operation

CHANNEL GROUPS

Radios are separated into groups of 16 channels each. Each group of 16 channels can be programmed to have an “individual personality” with its own set of operational features.

1. Select a channel group (if applicable) by pressing the **[GRP]** button and turning the Channel Selector knob. Press the **[GRP]** button again to return to channel select mode. See “GRP” on page 13.
2. Select a channel by turning the Channel Selector knob. When the unstopped channel selector is rotated past the highest (16th) channel, the radio will emit a beep and remain on the highest channel. When rotated past the lowest (1st) channel, the radio will emit a beep and remain on the lowest channel.

PROGRAMMABLE PUSH BUTTONS/ MICROPHONE FCN KEY MENU

When the radio is installed, labels are placed on the front push buttons to indicate their functions. An arrow on the display points to each front mounted push button that is active. The five push buttons can be programmed with the following functions:

Standard Functions		Optional Functions			
MON	Monitor Squelch Noise	TA	Repeater Talk Around	GSC	Group Scan
SCN	Channel Scan	CG	Channel Guard Disable	PA	Public Address
PRI	Priority Scan	HOM	Home Channel	ACC	Accessory 1
GRP	Group Select	SPK	Remote Speaker	ACC	Accessory 2
SQL	Squelch Adjust	NXT	Next Scan Channel	ACC	Accessory 3
		LPW	Low Power Select		

If an LAA0290 keypad microphone is used with the GMH radio, many of the functions above may also be enabled/disabled with the keypad [FCN] key.



- Press the **[FCN]** key to display the function menu.
- Repeatedly press **[FCN]** to step through the menu.
- Press **[PRI]** to toggle the function on/off when the desired menu item is displayed.
- When the display flashes, the function is enabled.
- Press **[ENT]** to exit the function menu.

MICROPHONE KEYPAD LOCK

To lock/unlock the microphone's keypad, press and hold the **[FCN]** key. "LOCKED" will be displayed and a low beep will sound if a key is pressed while the keypad is in the locked mode.

LOCKOUT EXCEPTION:

PTT unlocks the keypad during transmit for DTMF key presses.

PUSH BUTTON CONTROLS

MON Monitor Squelch Noise

Press the **[MON]** button to start or stop monitoring squelch noise. This allows you to set a comfortable volume level.

SCN Channel Scan

Press the **[SCN]** button to start or stop scanning channels in the scan list. The flashing SCN annunciator will appear on the display. Scan operation occurs only while the radio is not transmitting. If changes to the scan list are allowed, to add or delete the current channel from the Scan List, turn Scan and Priority Scan off, then press the **[SCN]** button and hold it down for 1 second or more.

PRI Priority Scan

Press the **[PRI]** button to start or stop priority scanning. The PR annunciator and the flashing SCN annunciator appear on the display. If changes to the Priority 1 channel are allowed, to make the current channel the fixed Priority 1 Channel, turn Scan and Priority Scan off, then press the **[PRI]** button and hold it down for 1 second or more.

GRP Group Select

Press the **[GRP]** button to toggle between Group Select and Channel Select Modes. Press the **[GRP]** button for Group Select Mode. Turn the Channel Selector knob to select a group. Return to Channel Select Mode by waiting 5 seconds, or by pressing the **[GRP]** button one time (numeric mode) or two times (alphanumeric mode). After selecting a group in Alphanumeric Mode, press the **[GRP]** button one time to display the Group Label, and a second time to return to Channel Select Mode.

SQL Squelch Adjust

Press the **[SQL]** button to toggle between Squelch Adjust and Volume Adjust Modes.

Press the **[SQL]** button for Squelch Adjust Mode. Turn the Volume knob to adjust the squelch setting. Turning the knob counter-clockwise tightens the squelch setting, allowing only stronger signals to open the squelch and be heard. In the absence of a held channel, the receiver will be tuned to the main channel. Guard qualification will be disabled during squelch adjustment.

Return to Volume Adjust Mode by waiting 5 seconds, or by pressing the **[SQL]** button again.

Pressing the **[SQL]** button and holding for more than 1 second sets the squelch to its factory preset value.

TA Repeater Talk Around

Press the **[TA]** button to turn Repeater Talk Around on or off. When TA is on, the radio transmits on the receive frequency of the selected channel, bypassing or “talking around” the repeater. This function may be used on any channel that is programmed to a frequency pair (repeater channel).

CG Channel Guard Disable

Press the **[CG]** button to disable or enable Channel Guard operation.

An arrow on the display points to the **[CG]** button indicating when Channel Guard is disabled. When Channel Guard is disabled the radio reverts to carrier squelch and all transmissions on the assigned receive frequency will be heard. When Channel Guard is enabled, a message is heard only when the proper Channel Guard is received. Transmit Channel Guard generation is unaffected. The **[CG]** button may also be used to override Busy Channel Lockout, if Busy Channel Override is installed.

HOM Home Channel

Press the **[HOM]** button to go to the pre-programmed Home Channel.

To set a different Home Channel, select the desired channel using the Channel Selector knob, press the **[HOM]** button, and hold it for more than 1 second until the arrow above the **[HOM]** button appears on the display. The new channel then becomes the Home Channel.

SPK Remote Speaker

Press the **[SPK]** button to toggle between the built-in radio speaker and a remotely mounted speaker.

NXT Next Scan Channel

Press the **[NXT]** button to select the next consecutive channel in the Scan List (not during scan operation).

LPW Low Power Select

Press the **[LPW]** button to toggle between high power and low power transmitter operation. Transmitter power settings can be programmed from 15 to 50 watts. If per-channel power is enabled, channels locked to low power will always transmit in low power mode regardless of the state of the **[LPW]** button.

GSC Group Scan

Press the **[GSC]** button to enable or disable Group Scan operation. During Group Scan operation, the following features are disabled: Priority Scan, User Channel Guard, and Nuisance Channel Delete.

Turn Group Scan off, then press the **[GSC]** button for 1 second or more to toggle the current group in or out of the Group Scan List.

PA Public Address

Press the **[PA]** button to turn the Public Address system on or off. When PA is on, pressing the microphone PTT switch causes audio to be routed to the audio amplifier without enabling the transmitter.

ACC Accessory

Press the **[ACC]** button to turn the installed accessory on or off. Up to three ACC buttons may be installed for different accessories.

SCAN OPERATION

RECEIVE

Scan operates only while the radio is not transmitting. The radio checks for signals on channels in the preset scan list, as well as the channel selected by the Channel Selector knob.

When a signal is detected, scanning stops and the message is received. The received channel is shown in place of the transmit channel.

Once the signal ends, the radio continues to monitor the channel for the preset scan delay time before it resumes scanning.

BASIC SCAN

1. Press the **[SCN]** button to enable Scan (an arrow will appear above the button).

2. If Priority Scan is enabled, press the **[PRI]** button to turn it off.

The display indicates Scan operation by flashing the **[SCN]** annunciator (alphanumeric mode) or by two flashing bars (numeric mode).

SCAN CHANNEL GUARD CHANNELS

1. Press the **[SCN]** button to enable Scan (an arrow will appear above the button).
2. If the **[CG]** button has an arrow over it, press the **[CG]** button once to turn Channel Guard Disable off.

When a signal is detected, scanning stops while the radio checks for the proper Channel Guard value. If the signal contains the proper Channel Guard value, the radio receives the message. Otherwise, the radio resumes scanning immediately.

NUISANCE CHANNEL DELETE

With Channel Scan on and Nuisance Channel Delete enabled, pressing and holding the **[SCN]** button for more than 1 second will temporarily remove a currently active channel from the Scan List. If the radio is equipped with a keypad microphone, pressing the **[CLR]** key while Scan is on will accomplish the same thing. Not all microphones support these functions. Contact your dealer to determine which features are available with your microphone and have been enabled in the radio. When the radio is powered off and back on, the pre-programmed Scan List will be restored.

TRANSMIT WITH SCAN ON

When operating in Scan mode, the radio transmits on the channel selected by the Channel Selector knob.

1. Select a transmit channel by turning the Channel Selector knob.
2. Press and hold the PTT switch and talk in a normal voice. When the PTT switch is released, the radio continues to monitor the selected channel for the preset scan delay time before it resumes scanning.

TALKBACK SCAN

If your radio is programmed for Talkback Scan, press PTT while a channel is active or while scan delay time remains. You will be responding on the transmit frequency of the received channel.

Talkback Scan will not work if Priority Scan is also on and your radio is programmed to always transmit on the Priority 1 channel.

CHANGE THE SCAN LIST

The radio can be programmed to enable the user to add or remove channels from the scan list. If user changes are enabled, follow these steps to change the scan list:

1. Turn Scan and Priority Scan off.
2. Select a channel to be added or removed from the scan list by turning the Channel Selector knob. If the channel is already on the scan list, SCN appears in the display.
3. Press and hold the **[SCN]** button for more than 1 second to toggle the channel on or off the scan list.

GROUP SCAN

Channels on each “Channel Scan List” in groups on the “Group Scan List” are scanned sequentially. The selected group is always scanned when Group Scan is enabled, even if that group is not on the Group Scan List.

When Group Scan is enabled, the following features are disabled:

- Priority Scan
- Dual Priority Scan
- User-Selected Channel Guard
- Nuisance Channel Delete
- Talkback Scan

PRIORITY SCAN

Priority Scan enables the radio to receive on any channel while monitoring for a message on the designated priority channel(s). The radio samples each priority channel at a preset rate (.25-2.0 seconds) regardless of activity on any other channel. Priority Scan operates only while the radio is not transmitting and can be used in combination with scan operation.

When Priority Scan is on, the PR annunciator illuminates, and the display flashes SCN (alphanumeric mode) or two flashing bars (numeric mode). If a message is received on a priority channel, the Priority indicator illuminates, and the radio receiver locks onto that channel for the duration of the transmission, unless a higher priority channel interrupts.

Priority Scan can be used in combination with Channel Guard with:

- Priority Scan on (arrow appears above **[PRI]** button)
- Channel Guard Disable off (no arrow above **[CG]** button)
- The Priority Channel(s) programmed with Channel Guard

If a message is received on a priority channel, the radio receiver locks on to the priority channel and checks to see if the proper Channel Guard value is present. If the signal contains the proper Channel Guard value, the radio receives the message. Otherwise, the radio will re-check the channel every 4 seconds, until the activity on the channel ceases.

DUAL PRIORITY SCAN

In each group, up to two of the 16 channels can be designated as priority channels. These two, PR1 and PR2, are periodically tested for activity, even if a different transmission is being listened to. Activity on PR2 preempts activity on any of the non-priority channels. Receptions on PR1 have priority over any other channel in the group, including PR2.

Either priority channel can be programmed as a fixed channel, tied to the Channel Selector knob, or programmed OFF. If the radio is programmed to transmit on the first priority channel, transmissions will occur on PR1 if PR1 isn't programmed OFF, when operating in Dual Priority Scan Mode.

If PR1 is a fixed channel, and changes to the 1st priority channel are allowed, the user can move the channel selector to a new channel and press and hold the **[PRI]** button for more than 1 second to choose a new PR1 channel.

Dual Priority Scan is automatically disabled when Group Scan is on.

OLD-STYLE BK PRIORITY SCAN

The radio can be programmed with one of three Priority Modes: A, B, or C. The table below shows how the priority channels and the transmit channels are selected in each mode.

	Mode A	Mode B	Mode C
Priority Channel	Channel Knob	Preset	Preset
Transmit Channel	Channel Knob	Channel Knob	Priority Channel

Priority Mode A With Scan

In Priority Mode A, the priority channel is set by the Channel Selector knob. Priority Mode A is seldom used by itself because the radio receives and transmits only on the knob-selected channel.

When Scan and Priority Mode A are enabled, scanning occurs until an active scan channel is found. The radio receives the message while continuing to check the priority (knob-selected) channel. The display shows the scan channel.

If the priority channel becomes active during this message, the Priority indicator illuminates. The radio changes to the priority channel and holds for the duration of the message. The display shows the priority channel.

To reply to a message on the priority channel, press the PTT switch and transmit on the priority channel. Once activity ceases on the priority channel, the radio returns to scan operation.

Priority Mode B

With Priority Scan on and Channel Scan off, the radio can receive on the knob-selected channel while sampling the priority channel. If the priority channel becomes active, the Priority indicator illuminates. The radio changes to the priority channel and holds for the duration of the transmission.

To reply to a message on the priority channel, turn the Channel Selector knob to the priority channel, and then transmit.

Priority Mode B with Scan

With Priority Scan and Channel Scan on, the radio scans until it locks onto an active channel. The radio continues to sample the priority channel while listening to the active scan channel.

If activity occurs on the priority channel, the radio overrides the active scan channel, changes to the priority channel, and holds for the duration of the transmission.

To reply to a message on the priority channel, turn the Channel Selector knob to the priority channel, and then transmit. Once activity has ceased on the priority channel, the radio returns to scan operation.

Priority Mode C

With Priority Scan on and Channel Scan off, the radio samples the fixed priority channel at the preset rate. If activity occurs on the priority channel, the radio switches to the priority channel and holds for the duration of the transmission.

To reply to a message heard on the priority channel, press the PTT switch. The radio transmits only on the priority channel when Priority Scan is on. Once activity has ceased on the priority channel, the radio returns to the receive channel on the Channel Selector knob.

Priority Mode C with Scan

With Priority Scan and Channel Scan on, the radio scans until it locks onto an active channel. The radio continues to sample the priority channel while listening to the active channel. If activity occurs on the priority channel, the radio overrides the active scan channel, changes to the priority channel, and holds for the duration of the transmission.

To reply to a message heard on the priority channel, press the PTT switch. The radio transmits only on the priority channel when Priority Scan is on. Once activity has ceased on the priority channel, the radio returns to scan operation.

CHANGE THE PRIORITY 1 CHANNEL

The fixed Priority 1 channel can be permanently set or can be changeable. If the radio has a changeable priority channel, use the following steps to make this change.

1. Turn Scan and Priority Scan off.
2. Turn the Channel Selector knob to the channel you want to enter as the new Priority 1 channel.
3. Press and hold the **[PRI]** button for more than 1 second. A short beep sounds and PR appears in the display, indicating that the displayed channel is now the priority channel.

NOTE: If the radio is programmed for Dual Priority operation, only Priority 1 channel can be changed with the **[PRI]** button.

NOTE: A channel can be the priority channel even if it is on the Scan List. Due to multiple sampling of the same channel, however, maximum performance occurs when the priority channel is not on the Scan List.

USER SELECTED CHANNEL GUARD

User Selected Channel Guard is only available on radios equipped with a keypad microphone. Not all microphones support this function. Contact your dealer to determine which features are available with your microphone and have been enabled in the radio.

When the radio is being programmed with transmit and receive frequencies for each channel, a receive Channel Guard value and a transmit Channel Guard value can also be assigned to each channel. If User Channel Guard Selection is enabled, the Channel Guard values for any channel can be copied to another channel in the radio. The CTCSS or CDCSS guard values will be copied

For example, to use the Channel Guard values of Channel 9 with the frequencies of Channel 5:

1. Turn Scan and Priority Scan OFF.
2. Turn the Channel Selector knob to Channel 5.
3. Press the **[9]** key on the microphone keypad. The display shows CG.

The radio will now operate on the frequencies of Channel 5 with Channel 9 Channel Guard values. The display shows the Channel Guard channel (9), and then the selected channel (5).

4. Press the microphone's **[#]** key to display the Channel Guard channel briefly. The display shows the group number, followed by the Channel Guard channel, and then the selected channel.
5. Press the **[0]** key to reset all values to the original programming, or press different number keys (1-16) to select a different set of Channel Guard Values.

NOTE: During Scan or Priority Scan, the receiver does not use the user-selected Channel Guard values. However, user-selected Channel Guard values are used by the transmitter in Scan Mode.

OTHER OPERATIONAL FEATURES

The BK Radio G Series radio is based on a microprocessor core that allows extra features and operational characteristics to be programmed into the radio. Your dealer can help define the best operational settings for your system and program them into the radio.

SCAN DELAY

Scan delay lets the radio receive a response to a transmission before scanning the other channels for activity. If you find that your scanner is restarting before message replies are received, you can ask your dealer to increase the scan delay time (0-7.5 seconds).

This timer is also used to allow for Talkback Scan.

HI/LO POWER

Each channel in the radio can be individually programmed to always transmit in low-power mode, regardless of the radio's **[LPW]** button (or microphone keypad **[FCN]** menu setting). If the programming for the channel allows high-power transmissions, the power level can be selected with the **[LPW]** button or the keypad **[FCN]** menu.

DTMF ENCODING

Radios with keypad-equipped microphones can be programmed to enable DTMF (Dual Tone Multiple Frequency) encoding. To send DTMF tones (similar to the tones used by a standard push-button telephone):

1. Press and hold the PTT switch.
2. Press any of the keys on the microphone's keypad.

You will hear a sidetone.

The FCN, PRI, ENT, and CLR keys respond as DTMF tones A, B, C, and D, respectively.

ANI ENCODING

ANI encoding (Automatic Number Identification), if enabled, transmits a sequence of DTMF tones each time you press the PTT switch. You will hear a sidetone. Your dealer can program the ANI number to be sent.

If DTMF and ANI are both enabled, the ANI tone sequence is transmitted only after the LAA0290 microphone's **[ENT]** key is pressed while the PTT switch is activated. You will hear a sidetone.

TIME-OUT TIMER

The transmit Time-Out Timer limits the duration of calls and guards against accidentally locking on the transmitter and tying up the radio system. Your dealer can program the duration of the Time-Out Timer (15-225 seconds, or disabled).

BUSY CHANNEL

If the radio has been programmed for Busy Channel operation, it will operate in one of the following three Modes:

- Busy Channel Indication
- Busy Channel Lockout
- Busy Channel Lockout with Override

BUSY CHANNEL INDICATION

The yellow Busy Channel Indicator glows if there is carrier activity on the selected channel. If the selected channel is a Channel Guard channel and the proper Channel Guard value is not detected, the Busy Channel Indicator remains on for the duration of the carrier activity and no message is heard. During Scan and Priority Scan operation, the Busy Channel Indicator glows when activity is detected on any channel on the Scan List.

When scanning or priority scanning Channel Guard channels with the **[CG]** (Channel Guard Disable) button OFF and activity has been detected, the Busy Channel Indicator glows for the time period necessary to determine if the proper Channel Guard value has been received. This will cause the Busy Channel Indicator to flash at various rates.

BUSY CHANNEL LOCKOUT

The Busy Channel Lockout feature applies only to those channels programmed with a receive Channel Guard value. When carrier activity is detected on the channel selected, the radio checks the receive Channel Guard value. If the proper Channel Guard value is present, the radio can transmit on that channel even if the **[CG]** button is off.

If the radio detects an incorrect value or carrier activity only, the transmitter is disabled. If an attempt is made to transmit, an alert tone will be generated and the display will show the word BUSY until the channel becomes available or the PTT switch is released, whether the **[CG]** button is on or off.

Channels not programmed with a receive Channel Guard value can be used to transmit regardless of carrier activity.

BUSY CHANNEL LOCKOUT WITH OVERRIDE

This mode operates in the same manner as Busy Channel Lockout except that the user can override and transmit by pressing the **[CG]**

button to disable receive Channel Guard (an arrow will appear over the button). The transmitter is locked out only if the **[CG]** button is off (no arrow above the **[CG]** button).

ALPHANUMERIC DISPLAY

The Alphanumeric Display can be programmed to operate in Numeric Mode, displaying channel numbers instead of labels.

Display enunciators indicate the following information:

ALPHANUMERIC INDICATION	
PR	-Priority Channel
PRG	-Programming Mode
TX	-Transmit
RX	-Receive
SCN	-Scan List Channel
	-Flashing SCN indicates scanning in progress, and RX SCN indicates receiving on a scanned channel.
CG	-User Channel Guard Active
GRP	-Group Label

GMH Series mobile radio displays can be programmed with the following features:

CHANNEL LABELS

You can program the radio with a label for each of the 25 channel groups and a label for each of the 16 channels within each group.

To display the channel number associated with a channel label:

1. Press the microphone's **[#]** key to display the group number.
2. Press the **[#]** key again to display the channel number.
3. Press and hold the **[#]** key to display the channel label.
4. Press the **[ENT]** key or wait for about 5 seconds to revert to normal radio operation.

Each label can include up to eight characters, with decimal points available between characters. Characters can include A-Z, 0-9, -, *, \$, /, +, %, \, |, _, <, >, h, or a blank space.

GROUP LABELS

The display can show group labels in addition to group numbers.

To display a group label, turn scanning functions off, then:

1. Press the microphone's **[#]** key to display the group number.
2. Press and hold the **[#]** key to display the group label.
3. Press the **[ENT]** key or wait for about 5 seconds to revert to normal radio operation.

DEFINITIONS AND ACRONYMS

ANI	Automatic Numeric Identification
CG	Channel Guard
CLR	Clear
Channel Guard	A subaudible tone, a code (analog) or a Network Access Code (digital) for selective calling and receiving.
DTMF	Dual Tone Multiple Frequency
DTMF Tones	Tones that sound like those used by a standard push-button telephone.
ENT	Enter
FCN	Function
GRP	Group
Individual Personality	The information programmed with a PC on both a global and by-channel basis that tells the radio exactly how to operate.
PR	Priority Channel
PRG	Programming mode
PRI	Priority
PTT	Push-To-Talk
RTA	Repeater Talk Around
RTX Channel	Ready-to-Transmit Channel
RX	Receive
SCN	Scan
SQL	Squelch
Squelch	A control that eliminates background noise.
Talkback Scan	When scanning, if a signal is present, the scan will stop and you will hear the signal. If you then push the PTT switch to talk back to the person, you are in Talkback Scan Mode.
Time-Out Timer	A feature that limits the duration of calls.
TX	Transmit

Programming Notes

Model Number: _____

Serial Number: _____

Master Password: _____

Front Panel Button Assignments:

#1 _____ #2 _____ #3 _____ #4 _____ #5 _____

Microphone Function Button Assignments:

FCN 1 _____ FCN 2 _____ FCN 3 _____ FCN 4 _____

FCN 5 _____ FCN 6 _____ FCN 7 _____ FCN 8 _____

FCN 9 _____ FCN 10 _____ FCN 11 _____

Home Channel: _____

Talkback Scan:

Enabled Disabled

Nuisance Channel Delete:

Enabled Disabled

Off Hook Scan:

Enabled Disabled

Notes: _____



RELM BK
RADIO

RELM Wireless Corporation
7100 Technology Drive
West Melbourne, FL 32904
1-800-648-0947
www.relm.com

P/N 7001-31000-000

REV. 12-07

